

# WHOLE HOUSE MULTI VENT UNIT

## Installation and Wiring Instructions

**Ref. N°  
478188**

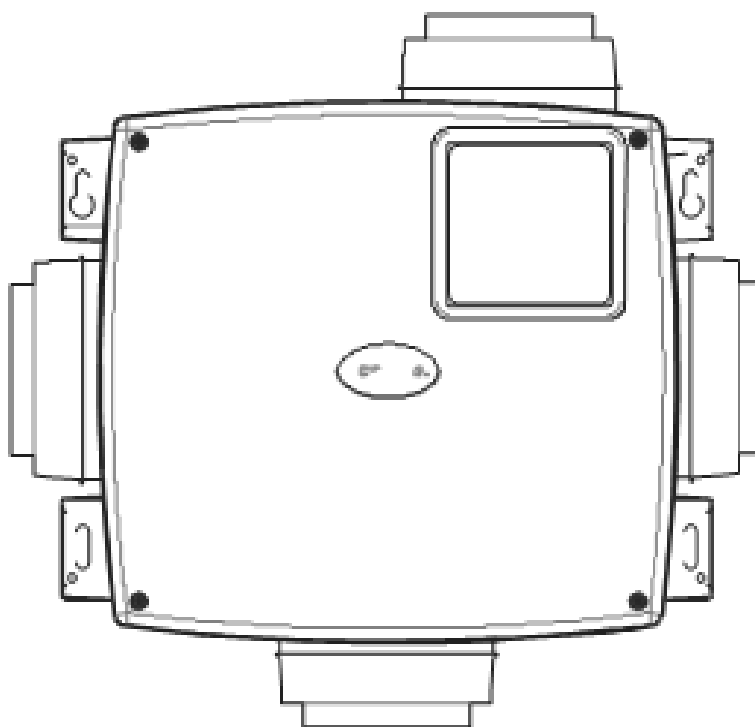

**PLEASE READ INSTRUCTIONS IN CONJUNCTION WITH THE ILLUSTRATIONS.  
PLEASE SAVE THESE INSTRUCTIONS**

IP22



## Installation and Wiring Instructions for the Whole house multi vent unit



### IMPORTANT:

### READ THESE INSTRUCTIONS BEFORE COMMENCING THE INSTALLATION

DO NOT install this product in areas where the following may be present or occur:

- Excessive oil or a grease laden atmosphere.
- Corrosive or flammable gases, liquids or vapours.
- Ambient exhaust air temperatures higher than 40°C or less than -5°C.
- Relative humidity above 90%
- Possible obstructions which would hinder the access or removal of the Unit.
- Sudden ductwork bends or transformations close to the Unit.

### SAFETY AND GUIDANCE NOTES

- All wiring must be in accordance with the current I.E.E. Regulations, or the appropriate standards of your country.
- The Unit should be provided with a local double pole isolator switch having a contact separation of at least 3mm. The fuse rating should be 3A.
- Ensure that the mains supply (Voltage, Frequency and Phase) complies with the rating label.
- The Unit should only be used in conjunction with the appropriate products.
- It is recommended that the connection to the terminal box is made with flexible cable/conduit.
- The Unit should not be sited within 600mm horizontally of/or 2250mm vertically of a bath/shower tray, in accordance with the current I.E.E. Regulations for bathrooms.
- When the unit is used to remove air from a room containing a fuel-burning appliance, ensure that the air replacement is adequate for both the fan and the fuel-burning appliance.
- The installer must ensure that the Unit intake is located a minimum of 600mm from any flue outlet.
- This Unit is designed as an inline ducted unit to be positioned between lengths of ducting. Short duct runs terminating within 1.5m must incorporate suitable guards unless the unit is mounted higher than 2.3m.
- This Unit should not be used where it is liable to be subject to direct water spray from hoses etc.
- This Unit handles moisture-laden air, ensure that a condensation drain is fitted.
- This appliance can be used by children aged from 8 years and above and persons with reduced physical, sensory and mental capabilities or lack of experience and knowledge if they have been given supervision or instruction concerning the use of the appliance in a safe way and understand the hazards involved.
- Children shall not play with the appliance.
- Certain applications may require the installation of sound attenuation material to achieve the sound levels required.
- Ducted ventilators must be ducted to the outdoors.

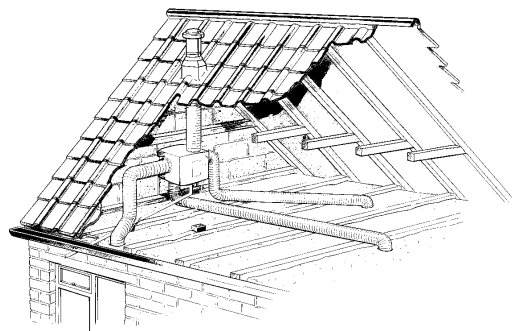

TYPICAL INSTALLATION

**INTRODUCTION NOTES**

The Unit is designed for simultaneous ventilation for a maximum of up to four separate areas such as bathrooms, kitchens and toilets. The range can be mounted in three different orientations for convenient installation in roof voids with a height of 250mm or greater. The Unit employs a highly efficient backward curved centrifugal motor impeller set. It is designed for continuous 24-hour use and should not be used in conjunction with a delay timer.

This product must be installed in accordance with the Domestic Ventilation Compliance Guide (England and Wales).

**SITING**

It is the responsibility of the installer to ensure that all aspects of system design are taken into consideration.

The unit is designed as a ducted unit and should only be used in ducted applications. Short duct runs, terminating close to the fan (i.e. within 1.5m), must incorporate suitable guards. Between two and four intake ducts may be used, three on the case sides and one in the base.

The unit may be mounted in three orientations.

- a). **Base mounted Installation** with ducting radiating out horizontally. The Condensate Drain is on the opposite side to the exhaust spigot at the base of the unit.

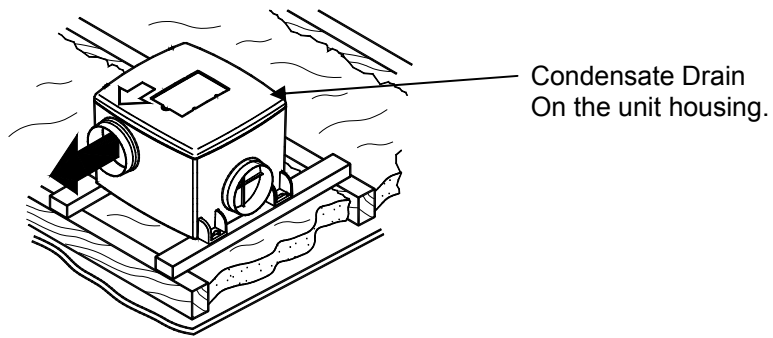

- b). **Vertically mounted Installation** with the exhaust spigot at top. The Condensate Drain is opposite to the exhaust spigot at the base of the unit. Additional drainage may be required from the duct connected to the bottom spigot.

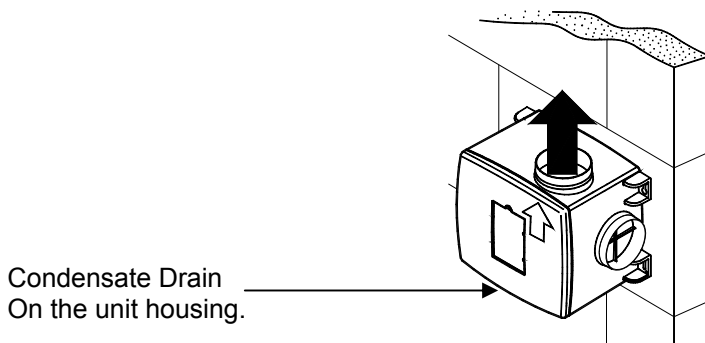

c). **Ceiling mounted Installation.** The Condensate Drain is opposite to the exhaust spigot under the lid of the unit. Additional drainage may be required.

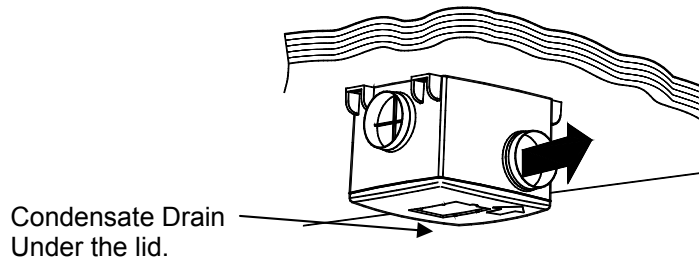

See the dimensional details below for the mounting hole positions.

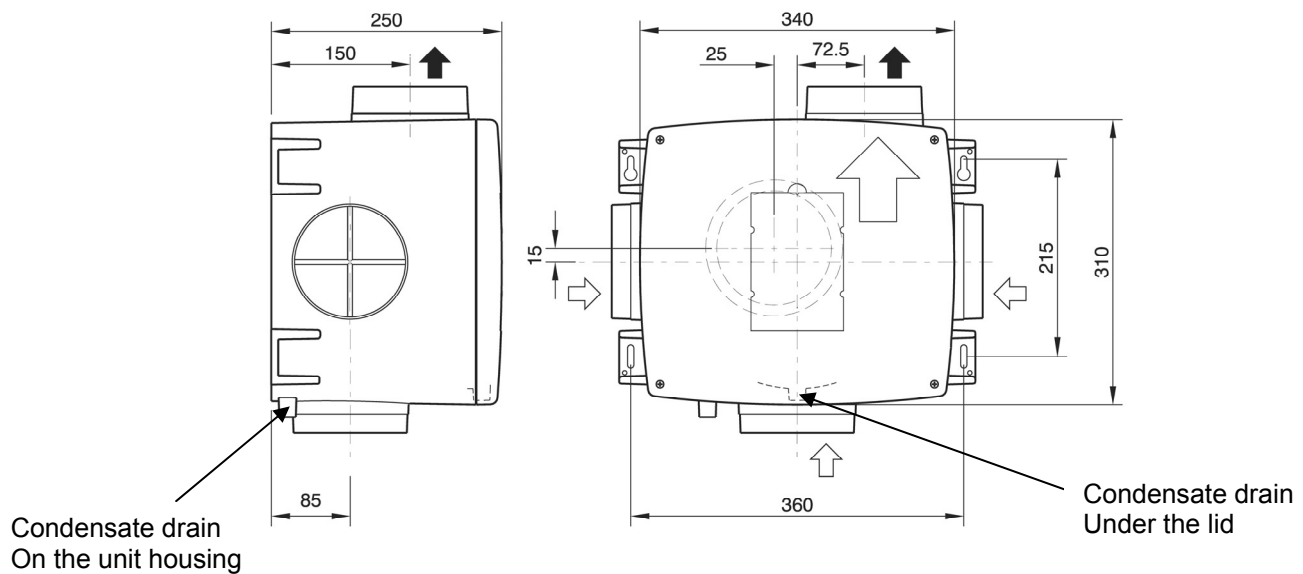

**INSTALLATION**

1. Position the Unit, taking into consideration the position of the rooms to be ventilated, the exhaust position, the drainage position and the electrical services. Ensure there is adequate access for installation and maintenance. Securely mount the Unit through the mounting brackets on the casing using the appropriate anti-vibration mounts, screws, washers, rubber bushes etc.
2. Where the intake and exhaust ducts are to be connected to the Unit, remove the spigot caps, if 125mm ducting is being used. If 100mm ducting is being used, peel out the centre of the cap with a screwdriver as indicated and leave the cap surround in position. To connect ducting to the base intake, use a suitable adaptor attached using the 4 holes provided.
3. Ducting passing through an unheated roof void should be insulated. Ducting runs should be as straight as possible and intake ducting should slope downwards from Under the lid. Connect ducting to the Units spigots and to appropriate ceiling terminations.
4. Select the drain spigot required, remove the “Knockout” and connect a suitable drainage system.

**WIRING**



**WARNING: THE UNIT AND ANCILLARY CONTROL EQUIPMENT MUST BE ISOLATED FROM THE POWER SUPPLY DURING THE INSTALLATION / OR MAINTENANCE.**

**THE UNIT MUST BE EARTHED.**

Access to the connection terminals is under the top cover which is retained by four screws. Ensure that the mains supply voltage, frequency, number of phases and power rating comply with the details on the rating label positioned under the top cover.

All wiring must be in accordance with local and/or national electrical codes as applicable or the appropriate standard in your country (BS7671 in the UK). The Unit must be supplied through a double-pole isolating switch, having a contact separation of not less than 3mm. Cable clamps are provided for use with the cable or flex on entry into the Unit.

To meet the stated energy efficiency rating, the Unit should be connected so that it can run at all three speeds. A possible wiring arrangement is shown in Figure 2.

Fig.1.  
Power connection for speed selection

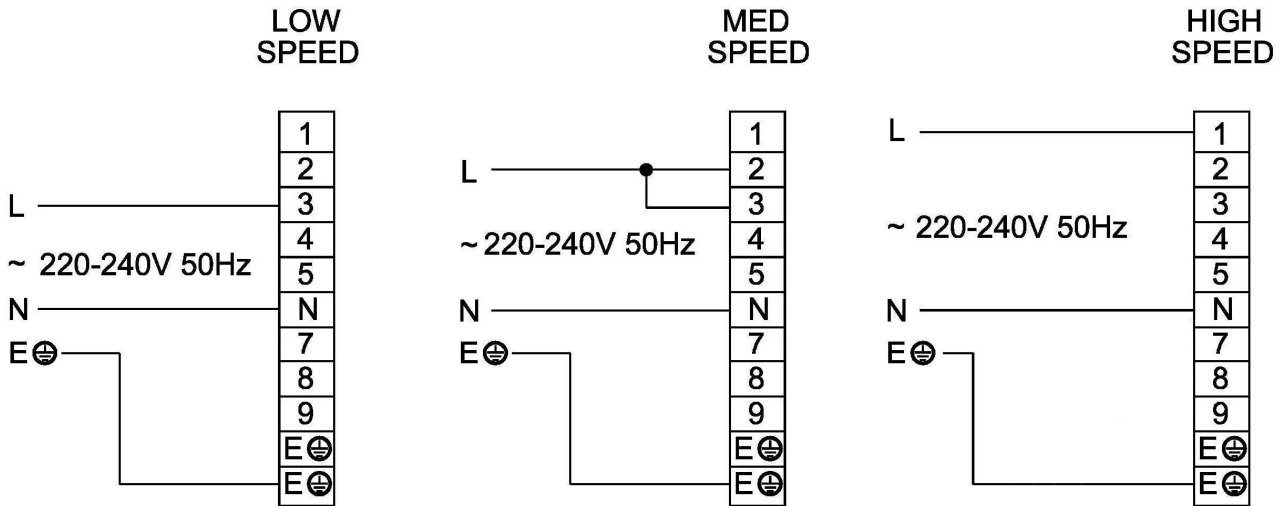
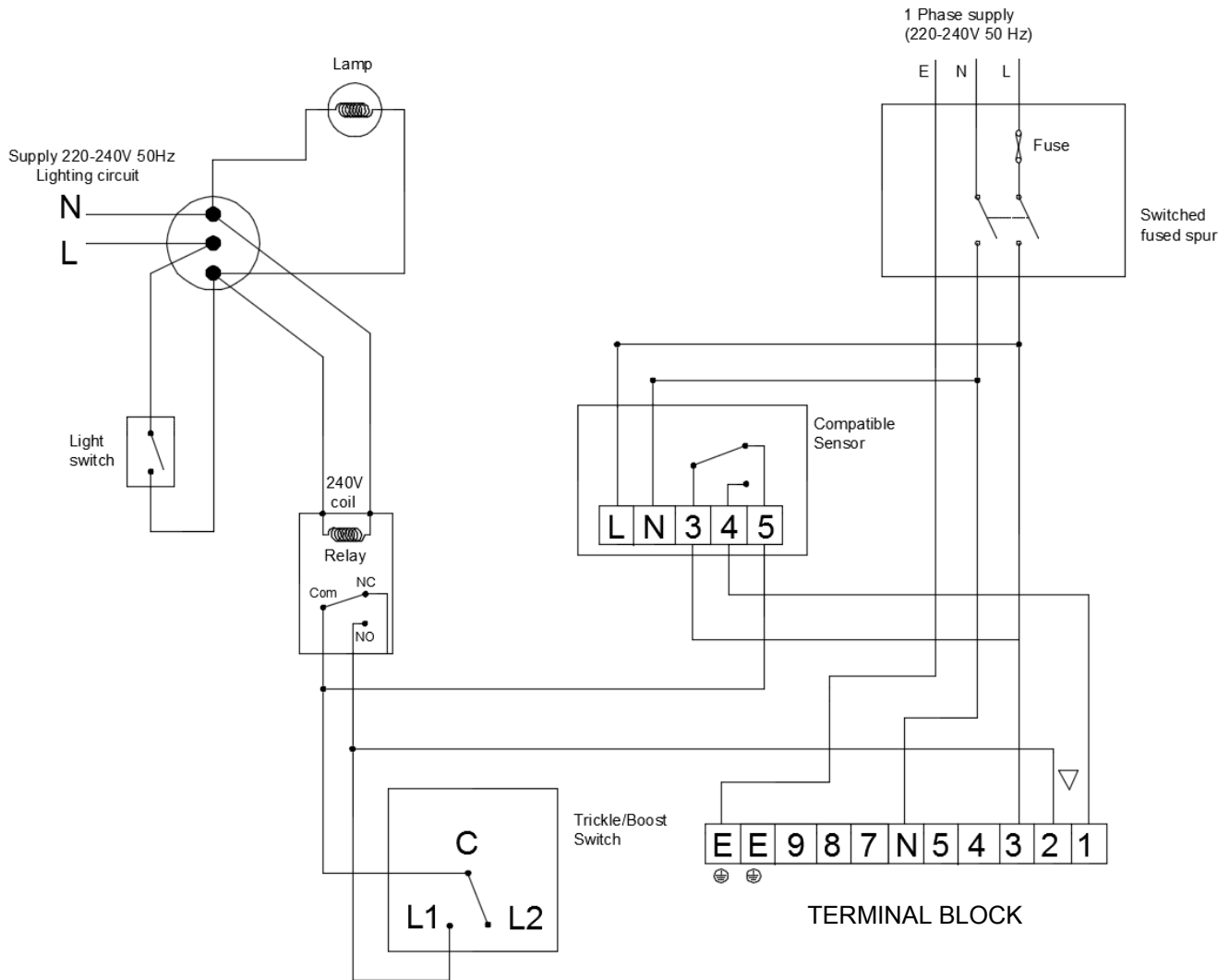

Fig.2.  
Example wiring for 3 speeds with three external sensors



### OVER-HEATING PROTECTION

The Unit motor is fitted with Standard Thermal Overload Protection. This will automatically switch the fan Off in the event of a fault condition.

If this occurs isolate the Unit, check for and remove any obstruction, leave for a short time for the motor to cool before reconnecting. If this recurs, Isolate the Unit and call a service engineer.

## PRODUCT FICHE

For Residential Ventilation Units (Complying Commission Delegated Regulation (EU)  
No 1254/2014)

|  |  |
|--|--|
| Name:  | PO BOX 1285 GB, CRAWLEY, RH10 OLY                  |
| Model ID (Stock Ref.) :  | 478188 - LDC                                       |
| SEC Class  | C  |
| SEC Value ('Average')  | -25.71   |
| SEC Value ('Warm')   | -10.21   |
| SEC Value ('Cold')   | -52.78   |
| Label Required? (Yes/No=Out of scope)  | Yes  |
| Declared as: RVU or NRVU/UVU or BVU  | RVU/UVU  |
| Speed Drive  | Multi-Speed  |
| Type HRS (Recuperative, Regenerative, None)  | None   |
| Thermal Eff: [ (%), NA(if none)]   | N/A  |
| Max. Flow Rate (m3/h)  | 489.6  |
| Max. Power Input (W): (@Max.Flow Rate)   | 63.3   |
| LWA: Sound Power Level (dB)  | 51.53  |
| Ref. Flow Rate (m3/s)  | 0.10   |
| Ref. Pressure Diff. (Pa)   | 185  |
| SPI [W/(m3/h)]   | 0.16   |
| Control Factor & Control Typology: (CTRL/ Typology)  |  |
| Control Factor; CTRL   | 0.65   |
| Control Typology   | Local Demand Control                               |
| Declared: -Max Internal & External Leakage Rates(%) for BVUs or carry over (for regenerative heat exchangers only),<br>-&Ext. Leakage Rates (%) for Ducted UVUs;   | <5% Internal, <5% External                         |
| Mixing Rate of Non-Ducted BVUs not intended to be equipped with one duct connection on either supply or extract air side;  | N/A  |
| Position and description of visual filter warning for RVUs intended for use with filters, including text pointing out the importance of regular filter changes for performance and energy efficiency of the unit | N/A  |
| For UVUs (Instructions Install Regulated Supply/Extract Grilles Façade)  | In F&W   |
| Internet Address (for Disassembly Instructions)  | <a href="http://www.anda.co.uk">www.anda.co.uk</a> |
| Sensitivity p. Variation@+20/-20 Pa: (for Non-Ducted VUs)  | N/A  |
| Air Tightness-ID/OD-(m3/h) (for Non-Ducted VUs)  | N/A  |
| Annual Electricity Consumption: AEC (kWh/a)  | 1.03   |
| Annual Heating Saved: AHS (kWh/a)  |  |
| AHS: Average   | 28.30  |
| AHS: Warm  | 12.80  |
| AHS: Cold  | 55.36  |



**Disposal**

This product should not be disposed of with household waste. Please recycle where facilities exist. Check with your local authority for recycling advice.